

ADM42

Integrated pulse & direction stepper motor driver

User Manual Rev. 1.0



Shenzhen Adam Technology Co Ltd

Catalog

Preamble 3	3
Overview 4	4
Product Introduction 4.....	4
Characteristics 4.....	4
Application field 5.....	4
Performance indexes 5	5
Electrical characteristics 5.....	5
Adaptation of standard motor6.....	5
Service Environment 6.....	6
Installation 7	7
Installation dimensions 7.....	7
Installation method 9.....	8
Driver Ports and Wiring 9	9
Wiring Diagram 9.....	9
Port Definition 10.....	9
Control signal input port 10.....	9
Dial code definition/15	12
Current setting 15.....	12
Subdivision setting 15.....	12
Parameter self-tuning function 16.....	13
Warranty and After-sales Service 16	13

preface

Thank you for using our integrated open-loop stepper drive.

Before using this product, please read this manual carefully for necessary safety information, precautions and operation methods. Incorrect operation can have very serious consequences.

This product is not designed and manufactured to protect personal safety from the threat of mechanical system. Please consider safety protection measures during the design and manufacturing of mechanical system to prevent accidents caused by improper operation or abnormal product.

The contents of this manual are subject to change without notice due to product improvements. Our company will not assume any responsibility for any modification of the product by the user.

When reading, pay attention to the following indications in the manual:



Note: You are reminded of the key points in the text.



Caution: indicates that wrong operation may cause personal injury and equipment damage.

Some of our products have passed the national compulsory 3C certification, CE certification and ROHS certification

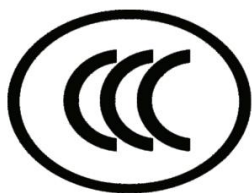

Overview

Product Introduction

ADM42 is a new digital integrated stepping driver of our company. The driver is designed with 32-bit DSP digital processing technology, variable current technology, low heating technology and other technologies. It has the advantages of low vibration, stable operation, low heating and high reliability. Users can set any subdivision in the driver 200–51200 and any current value output in the rated current through the serial port, which can meet the application requirements in most occasions. Thanks to the built-in micro-setechnology, even under the condition of low subdivision, the effect of high subdivision can be achieved. The low, medium and high speed operation is very stable and the noise is very small. The driver integrates the function of automatically adapting to the motor after being powered on, which can automatically generate optimal operating parameters for different motors and maximize the performance of the motor.

Characteristics

New 32-bit DSP technology

Low vibration, low-noise and stable operation

Built-in high subdivision and smoothing filtering functions

Parameter power-on automatic matching motor function

The variable current control greatly reduces the motor heating

The current is automatically halved at rest

Can drive 4, 6, 8 wire two-phase stepping motor

Photoelectric isolation single-ended signal input (pulse, direction and enabling)

Pulse response frequency up to 500KHz (factory default 200KHz)

Convenient current setting, optional between 0.5–2.2A

The subdivision setting range is 200–51200, and the higher subdivision can be customized

Over-voltage, undervoltage and overcurrent protection functions

Application field

It is suitable for all kinds of small and medium-sized automation equipment and instruments, such as carving machine, marking machine, cutting machine, medical equipment, laser setting, plotter, numerical control machine tool, automatic assembly equipment, etc. Excellent application effect in equipment with low noise, low vibration, low heating and high speed expected by users.

Performance index

Electrical characteristics

explain	ADM42			
	minimum value	Typical value	Maximum value	unit
Continuous output current	0.5	–	2.2	A
Supply voltage (DC)	15	24	32	Vdc
Control signal input current	6	10	16	mA
Control signal input current	–	5	–	Vdc
Minimum time width of pulse high level	1.5	–	–	US
Overvoltage voltage point	35			Vdc
Step pulse frequency	0	–	200	KHz
insulation resistance	100			M Ω

Applicable standard motor

The integrated drive can adapt to 42 open-loop hybrid stepper motors and linear screw stepper motors of different specifications of various motor manufacturers, and the drive can be sold separately. If it is necessary to purchase a complete set of our drive and motor products, we generally recommend the following two standard specifications and models. Stepping motors of other specifications and models or adaptive screw stepping motors can be customized according to customer requirements.

model	Holding torque	Motor body length	DRIVE THICKNESS	weight
	N. M)	Mm	Mm	Kg
ADM42-04	0.44	48 ± 1	± 1	0.5
ADM42-08	0.8	60 ± 1	± 1	0.6

Note: The driver can be customized to match any specification of 42 open-loop stepper motor and 42 open-loop linear screw motor

Service environment

Cooling mode		Natural cooling or forced air cooling
Service environment	occasion	It shall not be placed near other heated equipment. Dust, oil mist, corrosive gas, places with high humidity and strong vibration shall be avoided. Combustible gas and conductive dust are prohibited.
	temperature	-5°C~+50 °C
	humidity	RH~90%
	vibration	M/s ² MAX
Save temperature		-20°C~60 °C
Use of altitude		Below 1000m
weight		KG

Installation

Installation dimensions

ADM42 DRIVE SIZE

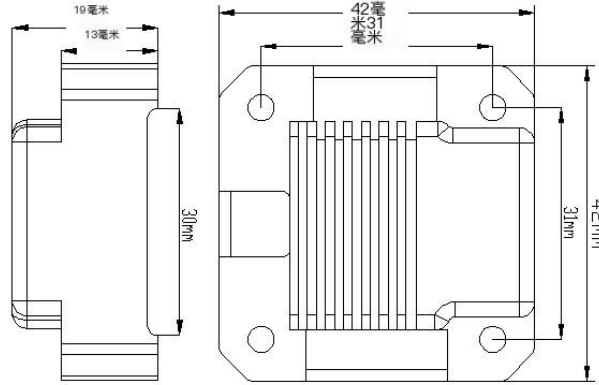

ADM42-04 Specification and Dimension of Drive Motor and Motor Torque Frequency Characteristic Curve

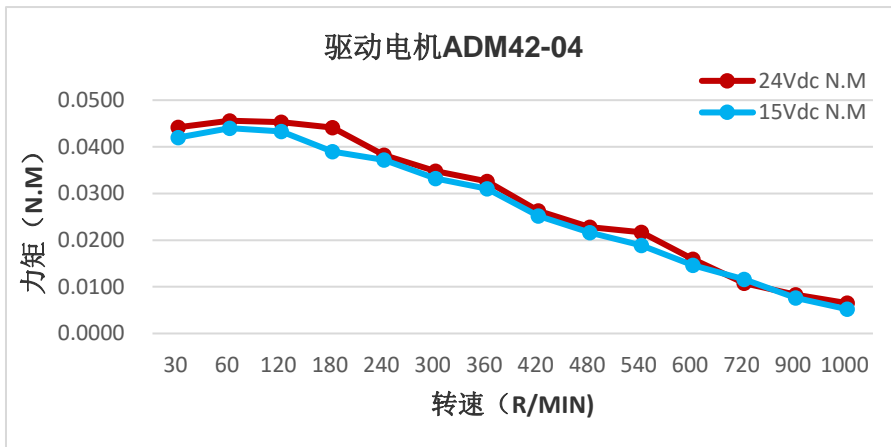
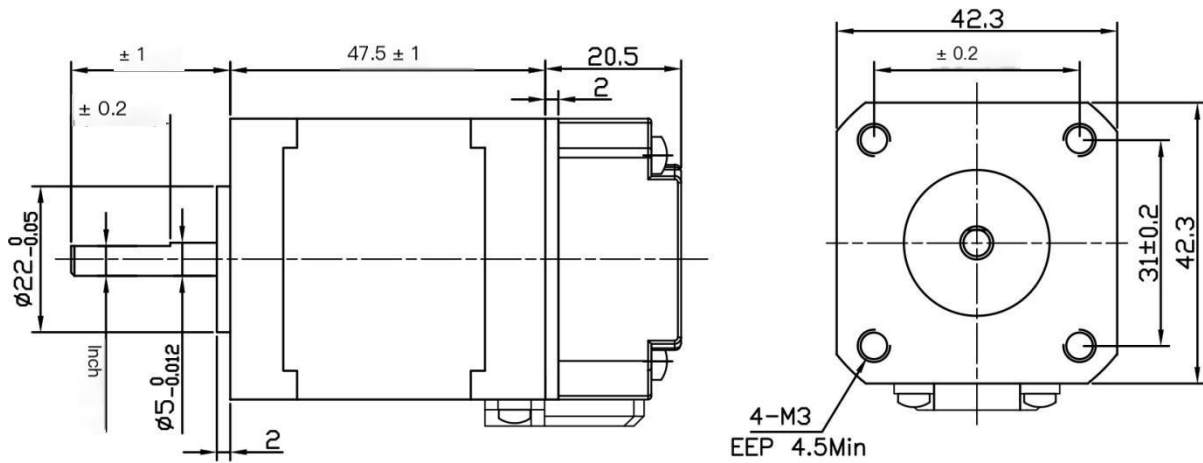

ADM42-08 Specifications and Dimensions of Drive Motor and Motor Torque Frequency Characteristic Curve

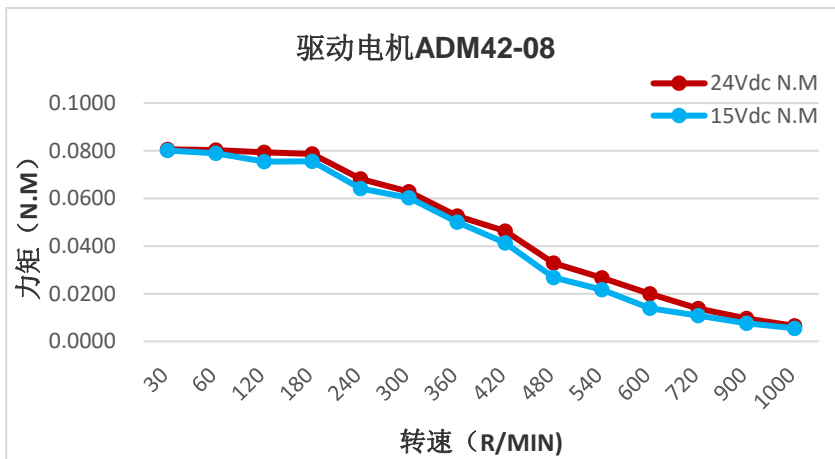
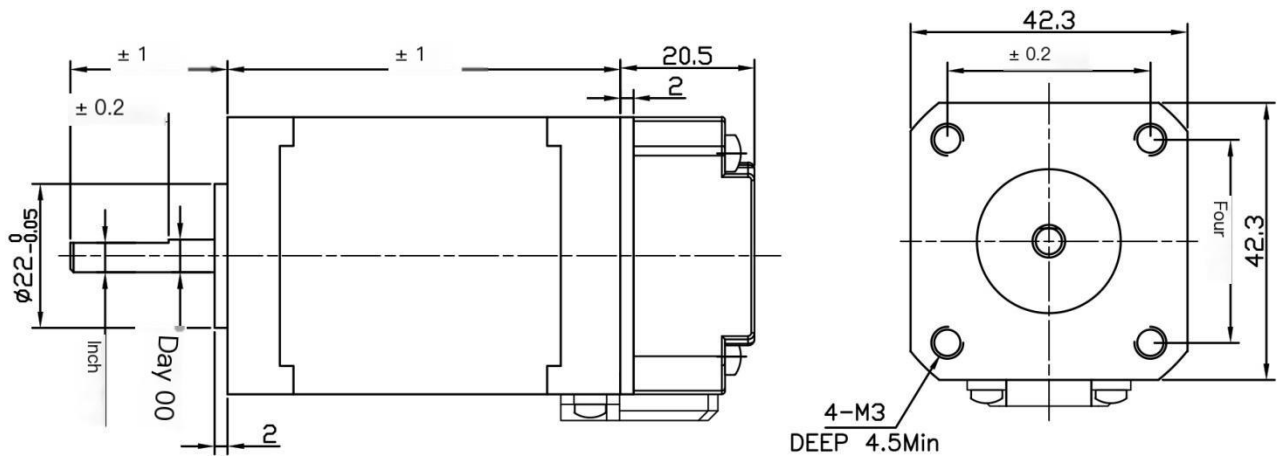

Installation method

The reliable operating temperature of the driver is generally within 60 °C, and the operating temperature of the motor is within 80 °C.

It is recommended to select the automatic half-current mode when the motor is stopped, and the current is automatically reduced by half to reduce the heating of the motor and the driver.

When installing the driver, please install it vertically on the side, so that the cooling teeth form strong air convection.

If necessary, install a fan near the driver for forced heat dissipation to ensure that the driver operates within the reliable operating temperature range.

Driver port and wiring

Wiring diagram

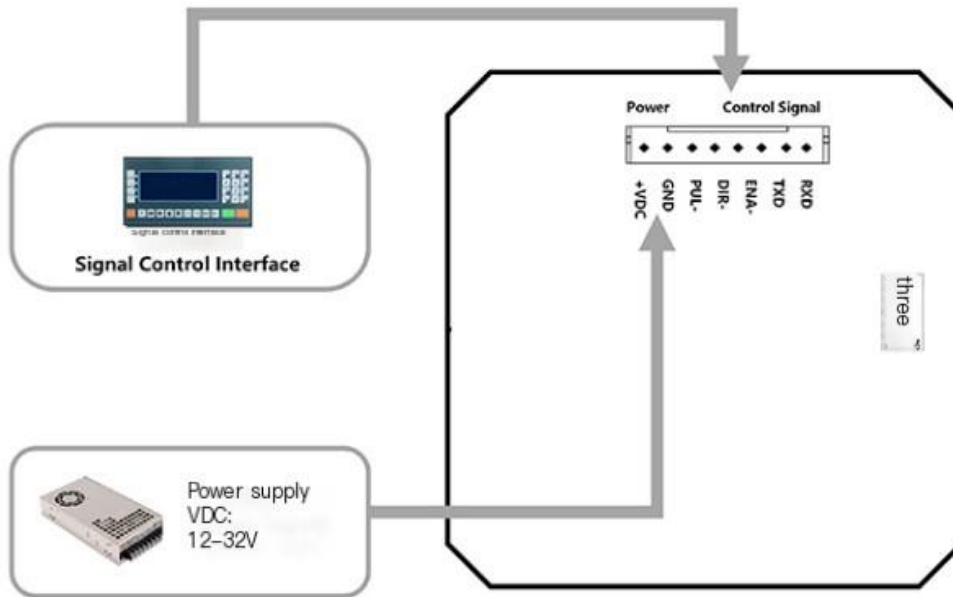

Port definition

LED status indication

The green LED is the power indicator, which is normally on when the driver is powered on; This LED turns off when the drive is de-energized or when the drive is faulty.

Control signal input port

Control signal interface

The control signal and power input port shall adopt the 2.0mm terminal of 8Pin.

Pin No	Signal name	Function description
1	Vdc	Positive input of power supply: DC voltage: 15-32Vdc; recommended DC: 24Vdc
2	GND	Negative input of power supply: GND of DC voltage

3	OPT0	Pulse, direction and enabling common anode input, DC 5Vdc. If 24Vdc, 2K/1W current-limiting and voltage-sharing resistor shall be connected in series
4	PUL -	Pulse control signal input (negative terminal)
5	DIR -	Direction control signal input (negative terminal)
6	ENA -	Enable control signal input (negative terminal)
7	TXD	TXD of serial port RS485, default serial port 232
8	RXD	RXD of serial port RS485, default serial port 232

Note: The signal level of pulse, direction and enabling interface can only accept 5V TTL level. If 24V is required, 2K Ω /1W current-limiting resistor shall be connected in series in front of the signal input port, or our company shall be informed to customize the product to only accept 24V TTL signal level when ordering.

Control signal interface circuit

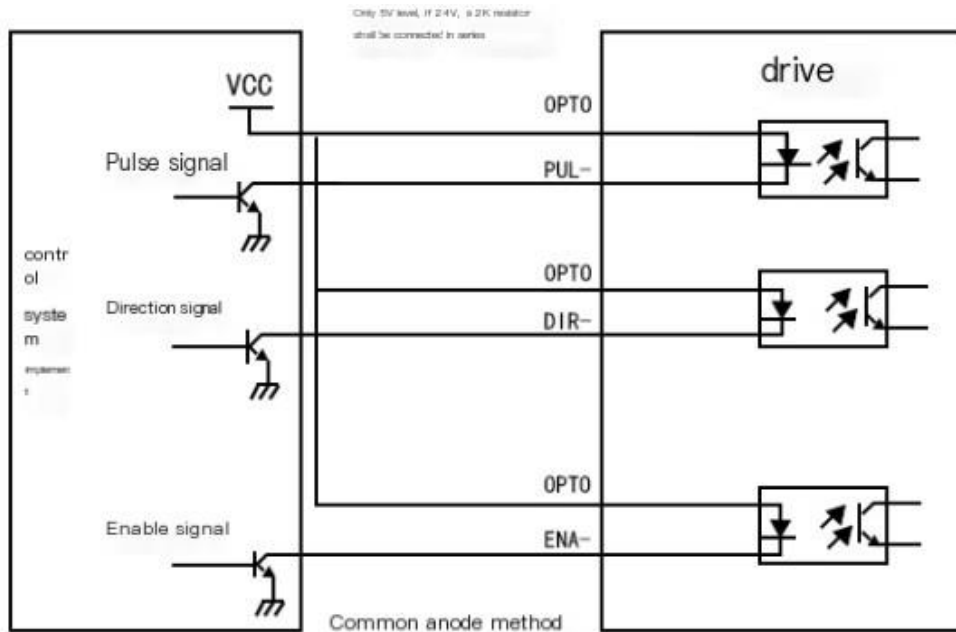

Control signal sequence diagram

To avoid some misoperation and deviation, PUL -, DIR - and ENA - shall meet certain requirements, as shown in the following figure:

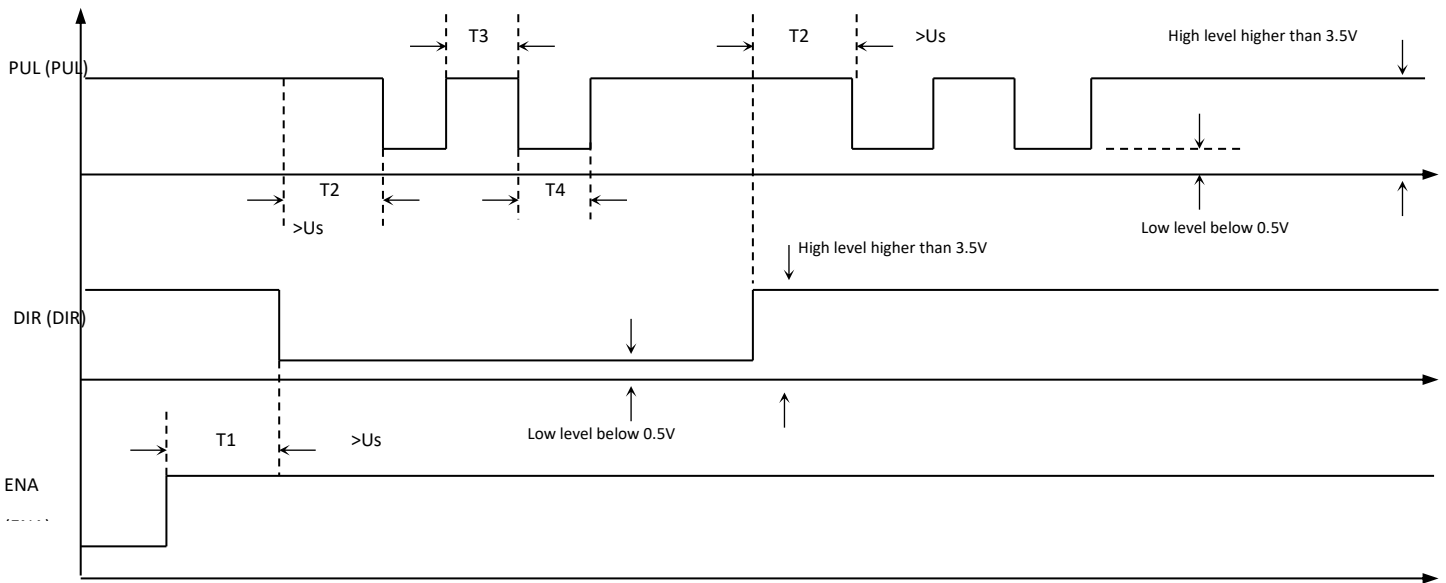

- Note:
- T1: ENA shall advance DIR by at least 5 μ s. Determined as high. Generally, it is recommended to be suspended;
 - T2: DIR at least advance PUL falling edge 1 μ S Determine whether the state is high or low;
 - T3: pulse width not less than 1.5 μ S;
 - T4: low level width not less than 1.5 μ S.

Power supply and motor output port

Motor interface

The motor wiring port adopts 4Pin 3.5mm terminal

Pin No	Signal name	Function description
1	A+	Two-phase stepping motor A+phase
2	A-	Two-phase stepping motor A-phase
3	B+	Two-phase stepping motor B+phase
4	B-	Two-phase stepping motor B-phase

The power supply voltage can work normally within the specified range, and the driver is preferably supplied by the non-regulated DC power supply, or transformer step-down+bridge rectification+capacitor filtering. However, it shall be noted that the peak rectified voltage

ripple shall not exceed the specified maximum voltage. It is suggested that users use DC voltage lower than the maximum voltage for power supply to avoid grid fluctuation exceeding the operating range of driver voltage.

If the regulated switch power supply is used for power supply, the output current range of the switch power supply shall be set to the maximum.

Please note that:

Attention shall be paid to the positive and negative poles of the power supply during wiring; It is better to use regulated power supply;

When the voltage is not stabilized, the current output capacity of the power supply shall be greater than 60% of the set current of the driver;

When the regulated switch power supply is used, the output current of the power supply shall be greater than or equal to the working current of the driver;

To reduce costs, two or three drives can share one power supply, but the power supply shall be sufficient.

Dial code definition

Current setting

Peak	RMS	SW1	SW2	SW3
Default[PK0. 5A, RMS=0. 35A]		on	on	on
0. 7A	0. 5A	off	on	on
1. 0A	0. 71A	on	off	on
1. 2A	0. 85A	off	off	on
1. 5A	1. 00A	on	on	off
1. 8A	1. 28A	off	on	off
2. 0A	1. 42A	on	off	off
2. 2A	1. 58A	off	off	off

Note: The above current is the standard product ADM42 current, and other currents can be derived according to the customer's requirements. The current range can be set to be any value between 0. 1 and 2. 2A.

Subdivision setting

Pulse/rev	SW4	SW5	SW6
Default[400]	on	on	on
800	off	on	on
1600	on	off	on
3200	off	off	on
4000	on	on	off
5000	off	on	off

6400	on	off	off
12800	off	off	off

Note: the above subdivisions are standard product adm42 subdivisions, and other subdivisions can be derived according to customer requirements. The set subdivisions range is any value between 200~25600.

Parameter self-tuning function

When the drive is open-loop stepping drive, the drive can automatically match the motor parameters after being electrified. Note that the pulse cannot be input at this time, the direction signal shall not change, and the enabling signal cannot be accessed.

Warranty and After-sales Service

Please keep the packing box for transportation, storage or use when it needs to be returned to our company for repair. One year warranty:

We are responsible for the warranty of any damage caused by the product itself within one year of use of the driver.

Not under warranty:

Damage caused by improper wiring, supply voltage and user peripheral configuration.

Without the written authorization of the Company, the user changes the product without authorization. Use beyond electrical and environmental requirements.

Drive serial number torn off or illegible.

The housing is visibly damaged.

Force majeure disaster.

After-sales service

Add WeChat or make a call

+86 156 5677 5078

Email: Simon@stepping-motor.cn

<https://www.adampower.de/controller>

Before calling, please record the following information:

Phenomenon of failure

Product Model and Serial Number

Date of installation or production